

ETC90

SP18

TS90

XS90

TRIOLOC



The Avant Easy Change interchangeable heads fit concisely and are variable in diameter and number of teeth. The alternative to carbide shank end mills when the depths of cut are small. The Avant Easy Change program is a proven solution – geared for maximum Q.

Fast, concisely
fitting changes

PROGRAMS
AVANT EASY CHANGE | TRIOLOC

T-SLOT MILLING CUTTERS

ETC90



T-slot milling cutters with highly precise indexable insert system
 Optimal power transmission through cross and/or star drive keys
 Extreme stability for long tool lives

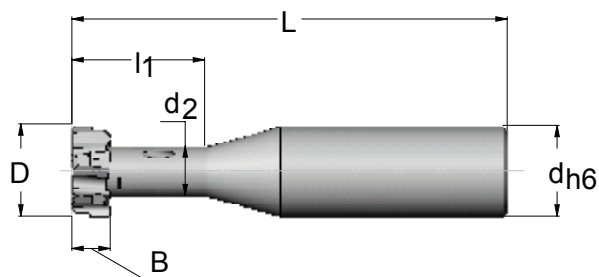

ETC90 Smooth shank tool holders								INS
Article	D	d ₂	d _{h6}	L	l ₁	lc	kg	
20G.20.1112.01	20	11	20	96	30	yes	0.18	ECT2008.R
20G.20.1313.01	24	13	20	100	35	yes	0.20	ECT2410.R
20G.25.1713.01	31	17	25	105	40	yes	0.37	ECT3113.R

Bigger diameters ET90 page 94

Data Interchangeable heads ECT				
Article	D	Z _{eff}	B	Weight in g
EC.T2008.32.01 SKY77	20	3	8.5	25.1
EC.T2410.33.01 SKY77	24	3	10	41.2
EC.T3113.33.01 SKY77	31	3	13	98.4

INTERCHANGEABLE HEADS EC

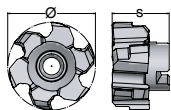

ECT							
AS	Ø			s			
3	20	24	31	08	10	13	
	20	24	31	13	15	18	

Matching of machining parameters
with the AV material groups

				Steel						
Article		Designation		A22	A21	A20	A19	A18	A17	A16
ECT2008...	EC.T2008.32.01 SKY77	ECT 200808 TR-25	h_{max}	0.11	0.1	0.1	0.08	0.05	-	-
			v_c	180-210	180-210	160-190	150-180	120-160	-	-
ECT2410...	EC.T2410.33.01 SKY77	ECT 241010 TR-25	h_{max}	0.11	0.1	0.1	0.08	0.05	-	-
			v_c	180-210	180-210	160-190	150-180	120-160	-	-
ECT3113...	EC.T3113.33.01 SKY77	ECT 311312 TR-25	h_{max}	0.11	0.1	0.1	0.08	0.05	-	-
			v_c	180-210	180-210	160-190	150-180	120-160	-	-

				Cast iron					
Article		Designation		D21	D20	D19	D18	D17	D16
ECT2008...	EC.T2008.32.01 SKY77	ECT 200808 TR-25	h_{max}	0.1	0.08	0.07	0.05	-	-
			v_c	180-240	170-230	150-200	140-170	-	-
ECT2410...	EC.T2410.33.01 SKY77	ECT 241010 TR-25	h_{max}	0.1	0.08	0.07	0.05	-	-
			v_c	180-240	170-230	150-200	140-170	-	-
ECT3113...	EC.T3113.33.01 SKY77	ECT 311312 TR-25	h_{max}	0.1	0.08	0.07	0.05	-	-
			v_c	180-240	170-230	150-200	140-170	-	-

INS

ECT2008...	08B.3514.7991	TX215
ECT2410...	08B.0520.7991	TX220
ECT3113...	08B.0520.7991	TX220

HIGH FEED MILLING CUTTERS

SP18

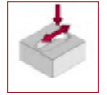

High feed milling cutter with high precision interchangeable carbide head system
 Optimal power transmission through cross or star drive keys
 Extreme stability for a long tool life

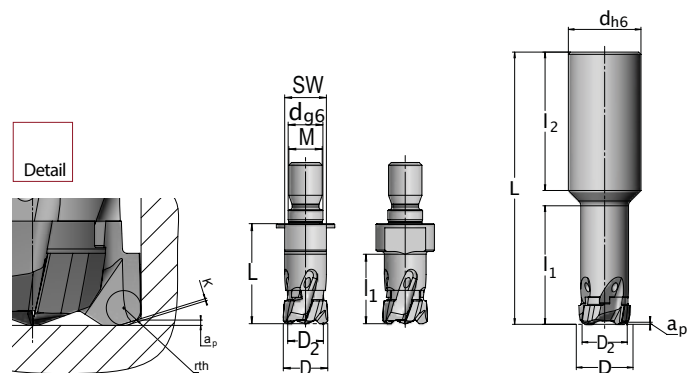

SP18 Smooth shank tool holders									INS
Article	D	dh6	L	l1	l2	lc	kg		
20G.20.1412.01	16	20	80	27	50	yes	0.15		ECK1612.R
20G.20.1422.01	16	20	95	42	50	yes	0.17		ECK1612.R
20G.20.1432.01	16	20	120	67	50	yes	0.20		ECK1612.R
20G.20.1723.01	20	20	100	48	50	yes	0.26		ECK2012.R
20G.32.2125.01	25	32	120	52	61	yes	0.53		ECK2512.R
20G.32.2135.01	25	32	150	82	61	yes	0.61		ECK2512.R

SP18 Screw-in tool holders									INS
Article	D	dg6	L	l1	M	SW	lc	kg	
20K.12.1412.01	16	12.5	36	25	12	15	yes	0.15	ECK1612.R
20K.16.2115.01	25	17	40	29	16	24	yes	0.16	ECK2512.R

Data Interchangeable heads ECK									
Article	D	D2	z _{eff}	a _p	r _{th}	K	Ramp	Weight in g	
EC.K1612.42.02 SKY77	16	12.8	4	0.8	2.0	0.26	3.8°	15.0	
EC.K2012.53.01 SKY77	20	13.5	5	0.75	2.5	0.29	3.1°	26.0	
EC.K2512.45.01 SKY77	25	19.9	4	0.8	2.0	0.26	2.3°	35.7	
EC.K2512.65.01 SKY77	25	17.9	6	0.8	2.5	0.41	2.3°	38.5	

INTERCHANGEABLE HEADS EC

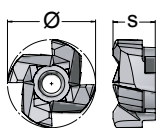

ECK				ECK			ECK		
AS	Ø		s	AS	Ø	s	AS	Ø	s
4	16	25	12	5	20	12	6	25	12
	16	25	12		20	12		25	12

Matching of machining parameters with the AV material groups

				Steel						
Article		Designation		A22	A21	A20	A19	A18	A17	A16
ECK1612..	EC.K1612.42.02 SKY77	ECK 161210 TR-25	h_{max}	0.8	0.8	0.65	0.6	0.55	0.5	0.45
			v_c	280-320	240-280	210-240	180-210	140-180	110-140	80-110
ECK2012...	EC.K2012.53.01 SKY77	ECK 201210 TR-28	h_{max}	0.7	0.7	0.6	0.55	0.5	0.45	0.4
			v_c	280-320	240-280	210-240	180-210	140-180	110-140	80-110
ECK2512...	EC.K2512.45.01 SKY77	ECK 251210 TR-25	h_{max}	1.0	0.85	0.85	0.8	0.75	0.7	0.55
			v_c	280-320	240-280	210-240	180-210	140-180	110-140	80-110
	EC.K2512.65.01 SKY77	ECK 251210 TR-28	h_{max}	0.65	0.65	0.55	0.5	0.45	0.4	0.35
			v_c	280-320	240-280	210-240	180-210	140-180	110-140	80-110

				Cast iron					
Article		Designation		D21	D20	D19	D18	D17	D16
ECK1612..	EC.K1612.42.02 SKY77	ECK 161210 TR-25	h_{max}	0.8	0.8	0.7	0.6	0.5	0.45
			v_c	340-380	280-340	240-280	210-240	180-210	140-180
ECK2012...	EC.K2012.53.01 SKY77	ECK 201210 TR-28	h_{max}	0.75	0.75	0.65	0.55	0.55	0.5
			v_c	340-380	280-340	240-280	210-240	180-210	140-180
ECK2512...	EC.K2512.45.01 SKY77	ECK 251210 TR-25	h_{max}	1.0	1.0	0.85	0.85	0.75	0.7
			v_c	340-380	280-340	240-280	210-240	180-210	140-180
	EC.K2512.65.01 SKY77	ECK 251210 TR-28	h_{max}	0.75	0.75	0.65	0.55	0.55	0.5
			v_c	340-380	280-340	240-280	210-240	180-210	140-180

INS		
ECK1612...	08B.3512.7991	TX215
ECK2012...	08B.0516.7991	TX220
ECK2512...	08B.0520.7991	TX220

Theoretical corner radius page 143
 Technical information ramp page 144

SHOULDER MILLING CUTTERS

TS90



Alternative to carbide shank end milling cutters in combination with small depths of cut
 Utmost change accuracy
 Form and force locking cross and/or star drive keys
 Ensures maximum smooth cutting

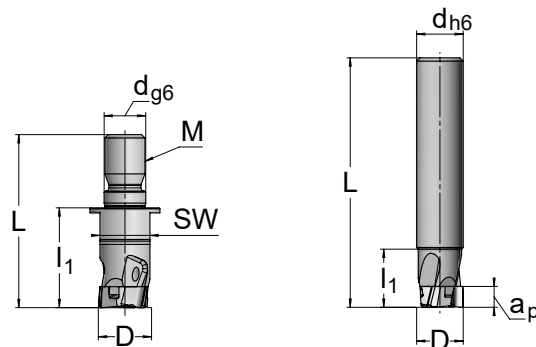

TS90 Smooth shank tool holders

Article	D	dg ₆	L	l ₁	lc	kg	INS
20G.14.1412.01	14	14	75	18	no	0.10	ECE1406.R
20G.14.1432.01	14	14	93.1	36	yes	0.10	ECE1406.R
20G.16.1612.01	16	16	82	22	no	0.12	ECE1606.R
20G.16.1632.01	16	16	104.1	44	yes	0.14	ECE1606.R
20G.18.1813.01	18	18	84	23	yes	0.15	ECE1808.R
20G.18.1833.01	18	18	108	47	yes	0.20	ECE1808.R
20G.20.2013.01	20	20	92	26	yes	0.20	ECE2008.R
20G.20.2033.01	20	20	118	52	yes	0.26	ECE2008.R

TS90 Screw-in tool holders

Article	D	dg ₆	L	l ₁	M	SW	lc	kg	INS
20K.12.1312.01	14	12.5	30	19	12	15	yes	0.10	ECE1406.R
20K.12.1512.01	16	12.5	30	19	12	15	yes	0.12	ECE1606.R
20K.12.1713.01	18	12.5	30	21	12	15	yes	0.15	ECE1808.R
20K.12.1913.02	20	12.5	30	21	12	17	yes	0.20	ECE2008.R

Data Interchangeable heads ECE

Article	D	Z _{eff}	a _p	Weight in g
EC.E1406.32.01 SKY77	14	3	6.0	5.9
EC.E1606.32.01 SKY77	16	3	6.0	7.9
EC.E1808.33.01 SKY77	18	3	8.0	10.9
EC.E2008.33.01 SKY77	20	3	8.0	13.6

INTERCHANGEABLE HEADS EC

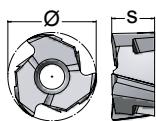

ECE						
AS	Ø				s	
3	14	16	18	20	06	08
	14	16	18	20	6	8

Matching of machining parameters
with the AV material groups

				Steel						
	Article	Designation		A22	A21	A20	A19	A18	A17	A16
ECE1406..	EC.E1406.32.01 SKY77	ECE 140606 TR-25	h_{max}	0.15	0.15	0.12	0.12	0.10	0.10	0.08
			v_c	280-320	240-280	210-240	180-210	140-180	110-140	80-110
ECE1606..	EC.E1606.32.01 SKY77	ECE 160608 TR-25	h_{max}	0.15	0.15	0.12	0.12	0.10	0.10	0.08
			v_c	280-320	240-280	210-240	180-210	140-180	110-140	80-110
ECE1808..	EC.E1808.33.01 SKY77	ECE 180808 TR-25	h_{max}	0.20	0.17	0.14	0.12	0.10	0.10	0.08
			v_c	280-320	240-280	210-240	180-210	140-180	110-140	80-110
ECE2008..	EC.E2008.33.01 SKY77	ECE 200810 TR-25	h_{max}	0.20	0.17	0.14	0.12	0.10	0.10	0.08
			v_c	280-320	240-280	210-240	180-210	140-180	110-140	80-110

				Cast iron					
	Article	Designation		D21	D20	D19	D18	D17	D16
ECE1406..	EC.E1406.32.01 SKY77	ECE 140606 TR-25	h_{max}	0.18	0.15	0.12	0.12	0.10	0.08
			v_c	290-340	270-300	240-280	210-240	180-210	140-180
ECE1606..	EC.E1606.32.01 SKY77	ECE 160608 TR-25	h_{max}	0.18	0.15	0.12	0.12	0.10	0.08
			v_c	290-340	270-300	240-280	210-240	180-210	140-180
ECE1808..	EC.E1808.33.01 SKY77	ECE 180808 TR-25	h_{max}	0.18	0.15	0.12	0.12	0.10	0.08
			v_c	290-340	270-300	240-280	210-240	180-210	140-180
ECE2008..	EC.E2008.33.01 SKY77	ECE 200810 TR-25	h_{max}	0.18	0.15	0.12	0.12	0.10	0.08
			v_c	290-340	270-300	240-280	210-240	180-210	140-180

INTERCHANGEABLE HEADS **EC**

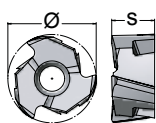

ECE						
AS	Ø				s	
3	14	16	18	20	06	08
	14	16	18	20	6	8

Matching of machining parameters
with the AV material groups

Article	Designation		Stainless steels				NF metals			
			C12	C11	C10	C09	E82	E81	E80	
ECE1406..	EC.E1406.32.01 SKY77	ECE 140606 TR-25	h_{max}	0.12	0.10	-	-	0.22	0.18	0.15
			v_c	120-200	100-160	-	-	650-1000	450-650	280-450
ECE1606..	EC.E1606.32.01 SKY77	ECE 160608 TR-25	h_{max}	0.12	0.10	-	-	0.22	0.18	0.15
			v_c	120-200	100-160	-	-	650-1000	450-650	280-450
ECE1808..	EC.E1808.33.01 SKY77	ECE 180808 TR-25	h_{max}	0.12	0.10	-	-	0.22	0.18	0.15
			v_c	120-200	100-160	-	-	650-1000	450-650	280-450
ECE2008..	EC.E2008.33.01 SKY77	ECE 200810 TR-25	h_{max}	0.12	0.10	-	-	0.22	0.18	0.15
			v_c	120-200	100-160	-	-	650-1000	450-650	280-450

INS



ECE1406...	08B.3511.7991	TX215
ECE1606...	08B.3511.7991	TX215
ECE1808...	08B.0516.7991	TX220
ECE2008...	08B.0516.7991	TX220

SHOULDER MILLING CUTTERS

XS90



Alternative to carbide shank end milling cutters
in combination with small depths of cut
Utmost change accuracy
Form and force locking cross and/or star drive keys
Ensures maximum smooth cutting

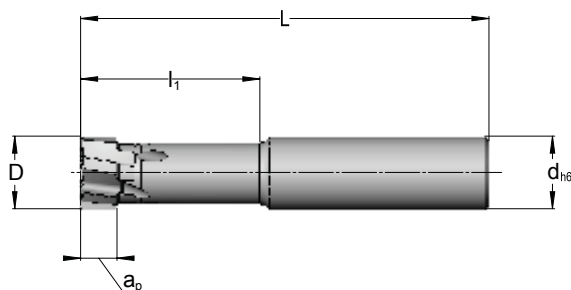

XS90 Smooth shank tool holders							INS
Article	D	d _{h6}	L	l ₁	lc	kg	
20G.16.1327.10	16	16	90	40	yes	0.12	ECE1612.R
20G.20.1624.10	20	20	100	48	yes	0.24	ECE2014.R
20G.25.2013.01	25	25	120	30	yes	0.42	ECE2512.R
20G.25.2033.01	25	25	130	71	yes	0.39	ECE2512.R
20G.25.2126.10	25	25	110	53	yes	0.36	ECE2516.R
20G.32.2526.10	28	32	120	58	yes	0.62	ECE2818.R

Data Interchangeable heads ECE				
Article	D	z _{eff}	a _p	Weight in g
EC.E1612.67.10 SKY77	16	6	8.0	33.0
EC.E2014.84.10 SKY77	20	8	10.0	33.0
EC.E2512.53.02 SKY77	25	5	8.5	40.8
EC.E2516.86.10 SKY77	25	8	12.5	63.6
EC.E2818.86.10 SKY77	28	8	15.0	100.0

INTERCHANGEABLE HEADS EC

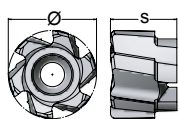

ECE			ECE			ECE						
AS	Ø	s	AS	Ø	s	AS	Ø			s		
5	25	16	6	16	12	8	20	25	28	14	16	18
	25	16		16	12		20	25	28	14	16	18.5

Matching of machining parameters with the AV material groups

Article	Designation	Recomm. a_e 0.7 x D	Steel						
			A22	A21	A20	A19	A18	A17	A16
ECE1612... EC.E1612.67.10 SKY77	ECE 161210TR-28	h_{max} v_c	0.16	0.16	0.14	0.14	0.12	0.10	-
			280-320	240-280	210-240	180-210	140-180	110-140	-
ECE2014... EC.E2014.84.10 SKY77	ECE 201410TR-28	h_{max} v_c	0.18	0.16	0.14	0.14	0.12	0.10	-
			280-320	240-280	210-240	180-210	140-180	110-140	-
ECE2512... EC.E2512.53.02 SKY77	ECE 251210TR-25	h_{max} v_c	0.20	0.18	0.15	0.15	0.13	0.11	-
			280-320	240-280	210-240	180-210	140-180	110-140	-
ECE2516... EC.E2516.86.10 SKY77	ECE 251610TR-28	h_{max} v_c	0.18	0.16	0.14	0.14	0.12	0.10	-
			280-320	240-280	210-240	180-210	140-180	110-140	-
ECE2818... EC.E2818.86.10 SKY77	ECE 281810TR-28	h_{max} v_c	0.18	0.16	0.14	0.14	0.12	0.10	-
			280-320	240-280	210-240	180-210	140-180	110-140	-

Article	Designation	Recomm. a_e 0.7 x D	Cast iron					
			D21	D20	D19	D18	D17	D16
ECE1612... EC.E1612.67.10 SKY77	ECE 161210TR-28	h_{max} v_c	0.16	0.15	0.14	0.14	0.10	0.10
			290-340	270-300	240-280	210-240	180-210	140-180
ECE2014... EC.E2014.84.10 SKY77	ECE 201410TR-28	h_{max} v_c	0.16	0.15	0.14	0.14	0.10	0.10
			290-340	270-300	240-280	210-240	180-210	140-180
ECE2512... EC.E2512.53.02 SKY77	ECE 251210TR-25	h_{max} v_c	0.18	0.16	0.15	0.15	0.11	0.10
			290-340	270-300	240-280	210-240	180-210	140-180
ECE2516... EC.E2516.86.10 SKY77	ECE 251610TR-28	h_{max} v_c	0.16	0.15	0.14	0.14	0.10	0.10
			290-340	270-300	240-280	210-240	180-210	140-180
ECE2818... EC.E2818.86.10 SKY77	ECE 281810TR-28	h_{max} v_c	0.16	0.15	0.14	0.14	0.10	0.10
			290-340	270-300	240-280	210-240	180-210	140-180

INTERCHANGEABLE HEADS **EC**

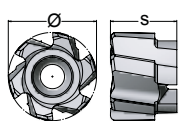

ECE			ECE			ECE						
AS	Ø	s	AS	Ø	s	AS	Ø			s		
5	25	16	6	16	12	8	20	25	28	14	16	18
	25	16		16	12		20	25	28	14	16	18.5

Matching of machining parameters with the AV material groups

	Article	Designation	Recomm. a_e 0.7 x D	NF metals		
				E82	E81	E80
ECE1612...	EC.E1612.67.10 SKY77	ECE 161210 TR-28	h_{max}	0.15	0.15	-
			v_c	650-1000	450-650	-
ECE2014...	EC.E2014.84.10 SKY77	ECE 201410 TR-28	h_{max}	0.15	0.15	-
			v_c	650-1000	450-650	-
ECE2512...	EC.E2512.53.02 SKY77	ECE 251210 TR-25	h_{max}	0.15	0.15	-
			v_c	650-1000	450-650	-
ECE2516...	EC.E2516.86.10 SKY77	ECE 251610 TR-28	h_{max}	0.15	0.15	-
			v_c	650-1000	450-650	-
ECE2818...	EC.E2818.86.10 SKY77	ECE 281810 TR-28	h_{max}	0.15	0.15	-
			v_c	650-1000	450-650	-

INS



ECE1612...	08B.0416.7991	TX215
ECE2014....	08B.0520.7991	TX220
ECE2512....	08B.0520.7991	TX220
ECE2516....	08B.0627.7991	TX225
ECE2818....	08B.0627.7991	TX225